

Challenges of a First Time SOC design in an Embedded Systems Design Project Course

Dr. Mark C. Johnson, Vikram Anand, Thomas Bottonari,
Bryan Hermsen, Curtis Verner, Prof. David G. Meyer

School of Electrical and Computer Engineering, Purdue University,
465 Northwestern Avenue, West Lafayette, Indiana, USA, 470907

<mcjohnso|vanand|tbottona|bhermsen|cverner|meyer>@purdue.edu

ABSTRACT

Undergraduate embedded systems design courses typically require students to integrate a microcontroller with commercially available sensors and output devices[1]. This is extremely valuable, but many applications have emerged for which a simple microcontroller is not sufficient due to high performance, power efficiency, or unusual interface requirements. SOC (System on a Chip) course projects typically use an existing prototyping system as all or most of the circuit implementation[2]. This too provides a valuable learning experience, but does not address the packaging and system related issues that occur when integrating all devices in a package of one's own design. The project reported in this paper addressed both aspects of the system design. The student designers successfully implemented an application called "Hooked on Harmonix" (a piano training system) using a soft processor and custom logic on an FPGA along with a USB controller, MIDI synthesizer, and power regulators on a custom printed circuit board (PCB). In this paper we present the design, the results, and an overview of how the digital systems project course fits into the ECE curriculum with a focus on the challenges involved in designing and integrating an SOC as part of a packaged system design.

1. INTRODUCTION

Since 1999, students have been practicing "system on a printed circuit board (PCB)" design in ECE477 Digital Systems Senior Design Project. These designs incorporate most but not all aspects of SOC design including software or firmware development and integration of input/output devices with a microcontroller as a part of a fully packed system including a custom designed printed circuit board. Pre-requisite courses in the Computer Engineering curriculum (ECE337 ASIC Design Laboratory, ECE362 Microprocessor Systems and Interfacing, and ECE437 Computer Design and Prototyping) provide students with the theory and practice of techniques necessary to augment the computational and interface capabilities of a microcontroller. However, the one piece of SOC design usually missing from this digital systems senior design project course is the practice of augmenting the capabilities of a microcontroller with custom logic design.

In the fall of 2007, a team of four students in the senior design project course implemented and demonstrated a project which addressed this missing aspect of SOC design. While the one semester time frame of the course doesn't permit fabrication of an SOC on custom silicon, it is possible with modern Field Programmable Gate Arrays (FPGAs) that allow integration of custom logic with a microprocessor soft core. Using an Altera EP2C20 Cyclone II™ FPGA, the student team implemented a piano training (or gaming) system called "Hooked on Harmonix." The system presents notes to be played as vertically descending bars a VGA display placed above a MIDI (Musical

Instrument Digital Interface) keyboard. As the music is presented to the user, the system monitors the accuracy with which the user is able to follow the music. USB memory device and MIDI keyboard interfaces are managed by the NIOS II processor. Graphics processing and control of the entire system take place in custom logic on the FPGA. The remaining circuit functions are integrated as separate components with the FPGA and FPGA configuration device on a custom PCB.

2. THE DESIGN

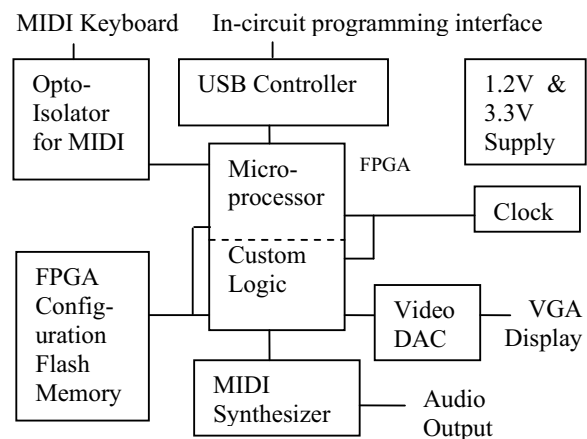

Figure 1 System Block Diagram



Figure 2 PCB in Packaging

Figure 1 identifies the major components and architecture of the system. An Altera Cyclone II™ FPGA is configured to support a NIOS II soft core processor along with custom logic used primarily for video processing. An opto-isolator and MIDI connector provide the hardware portion of the MIDI interface to the microprocessor. An ISP1181A USB controller enables in-circuit programming of the FPGA. An

Analog Devices ADV7125 permits digital video data from the FPGA to drive a VGA display. A Rohm BU8793KN sound synthesizer chip commonly used for mobile phones provides audio output. These components plus the voltage regulator, clock circuit, and various discrete passive components were integrated onto a single 4-layer PCB. The PCB is shown in the system enclosure with an access lid removed in Figure 2.

3. CHALLENGES

Integrating a soft-core processor, custom logic, and a number of supporting components presents students with a blend of challenges that is relatively unique for an undergraduate course project, though not unusual for industrial designs. PCB based embedded system designers must deal with component selection, hardware/software integration, and careful design of the PCB to avoid signal integrity problems. FPGA based SOC designers must deal in much greater depth with the hardware-software partition and decide how to best integrate the custom logic with an embedded soft core. For this project, the students had to contend with both sets of issues as well as designing the PCB to accommodate the FPGA, an FPGA configuration device, and an in-circuit FPGA programming interface. Such a project also significantly increases the variety of development software that must be employed. Most of the development tools were already familiar either to the course staff or the students themselves, but the software development tools and the design flow for integration of the processor and custom logic were new to all involved.

The primary PCB layout challenge was the packaging of the FPGA. In this project course, students are required to design their own PCB which is fabricated at an outside vendor. The students then must solder the parts on the PCB themselves. This rules out the use of parts such as BGA (Ball Grid Array) devices. The students settled on a 240 pin PQFP (Plastic Quad Flat Pack) EP2C20 Cyclone II device which was the largest available device from Altera in a PQFP. Numerous power and ground connections to the FPGA along with appropriate bypass capacitors, greatly added to the challenge of routing other signals to and from the FPGA. Most projects in this course are done with two-layer PCBs, but in this case the students were permitted to use a four-layer board so that power and ground planes could be used.

With respect to the software design, the main challenge was the partition of functionality between software and custom logic. Surprisingly, the control flow and user interface management were done as a state machine in hardware rather than in software. Because the control flow of the system was so closely tied to the data on the screen, it proved to be most convenient to handle the control flow as close as possible to the graphics control logic which required a hardware implementation to meet video data rate requirements. The NIOS processor's primary jobs were to load MIDI data files from flash memory, parse the MIDI data, and send MIDI data to the audio synthesizer and to the display controller hardware in synchronization with each other.

4. RESULTS

The student design team was successful in delivering a functional design that performs well and is attractively

packaged as shown in Figure 3. During integration of the PCB some corrections became necessary and were accomplished by means of "fly wiring" and a small supplementary circuit board which are visible in Figure 2. The small circuit board was required to work around a component footprint (the MIDI synthesizer) for which the pin locations were exactly reversed relative to the actual device. There was one noticeable limitation in functionality. The system, as delivered, did not provide user control of tempo. As a result, if the MIDI data file being played was created with a fast tempo, it could be very difficult for the user to follow the notes with their hands. This can be corrected in software given additional time for design and testing. An internet archive of past senior design projects includes a video and documentation of the project[3].

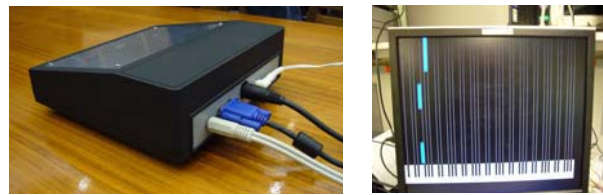

Figure 3 Packaged System in Use

5. CONCLUSIONS

It is already challenging to take an idea for an embedded systems product from concept to a packaged well integrated product in the course of one semester. The design team for Hooked on Harmonix chose a more aggressive goal by deciding to integrate a soft processor and custom logic into their product even though it would increase the number of tools and design techniques to be learned and applied. The design team achieved all of their objectives and created a very engaging product. It is the author's hope that this will encourage future students and instructors at Purdue University and elsewhere to incorporate reconfigurable logic, soft processors, together with more traditional PCB based approaches in their student design projects.

6. ACKNOWLEDGEMENTS

The authors wish to thank Altera Corp. for their generous provision of devices, development boards, and development software to support this and many other student design projects and Mentor Graphics Corp. for use of the Modelsim™ logic simulator.

REFERENCES

- [1] S. Nooshabadi and J. Garside, "Modernization of Teaching in Embedded Systems Design—An International Collaborative Project," *IEEE Transactions on Education*, IEEE, USA, pp. 254-262, May 2006.
- [2] J.O. Hamblen, "Using an FPGA-based SOC Approach for Senior Design Projects", *Proceedings of the 2003 IEEE International Conference on Microelectronic Systems Education, MSE'03*, USA, pp. 18-19, 1-2 June 2003.
- [3] V. Anand, T. Bottonari, B. Hermson, C. Verner, "Hooked on Harmonix, Documentation," December 2007, <http://cobweb.ecn.purdue.edu/~dsml/ece477/Webs/F07-Grp02/Documents/Documents.html>, accessed April 3, 2008.